

Technical Specification

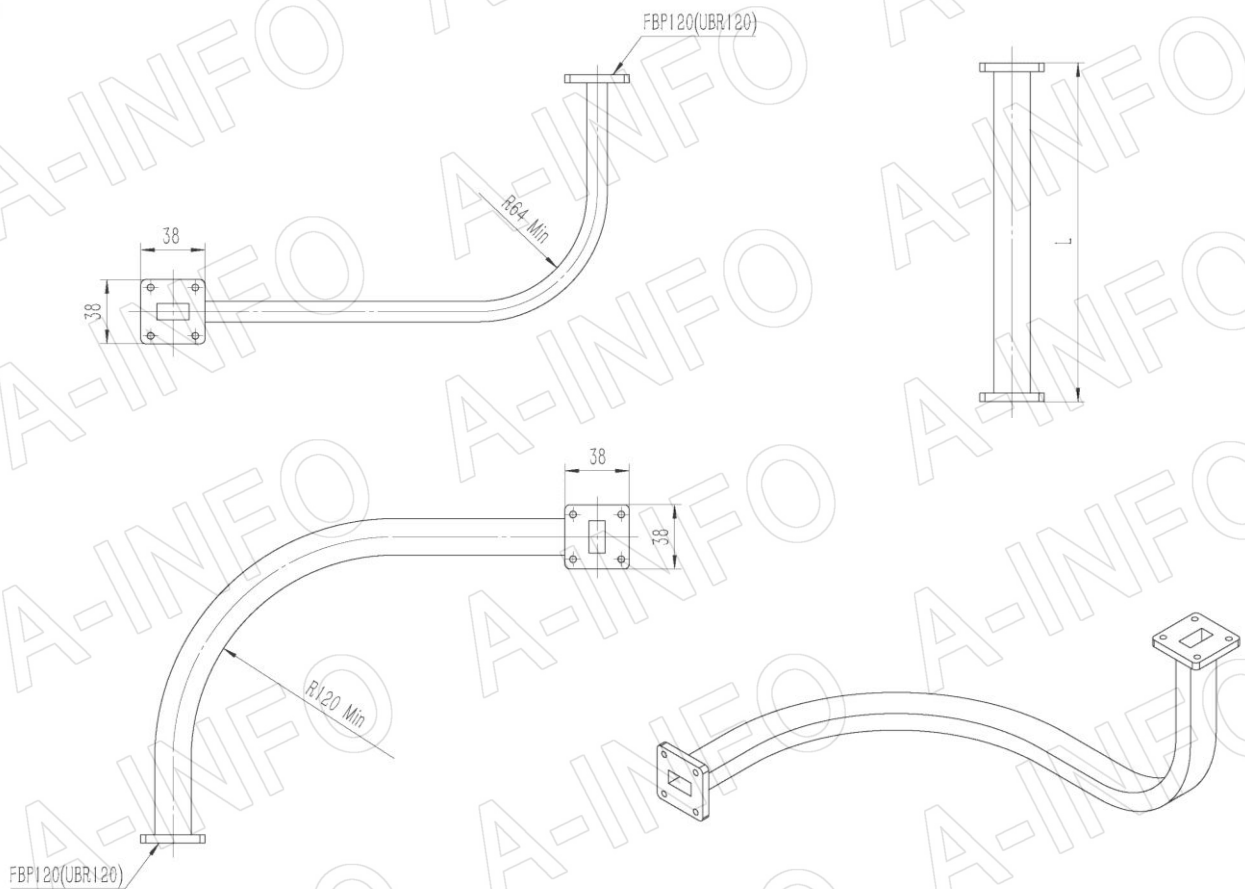

EIA WR	WR75
Frequency Range(GHz)	10.0 – 15.0
Attenuation(dB/m)	0.65 Max.
VSWR	1.20:1 Max.
Average Power(KW CW)	1.5
Max. Air Pressure(Mpa)	0.2
Min. E-Bend Radius(mm)	64
Min. H-Bend Radius(mm)	120
Flange	FBP120(UBR120)
Jacket	Rubber
Operating Temp.(°C)	-55 ~ +85
Material	Cu
Length(mm)	500
Net Weight(Kg)	0.28 Around

Outline Drawing (Size: mm)



AINFO Inc.

Page 1 of 3

China(Beijing): Tel: (+86) 10-6266-7326,
China(Chengdu): Tel: (+86) 28-8519-2786,
USA: Tel: (+1) 949-639-9688,

(+86) 10-6266-7327 Fax: (+86) 10-6266-7379
(+86) 28-8519-3044 Fax: (+86) 28-8519-3068
(+1) 949-639-9608 Fax: (+1) 949-639-9670

Website: www.ainfoinc.com
Email: sales@ainfoinc.com

Flange Drawing (Size: mm)

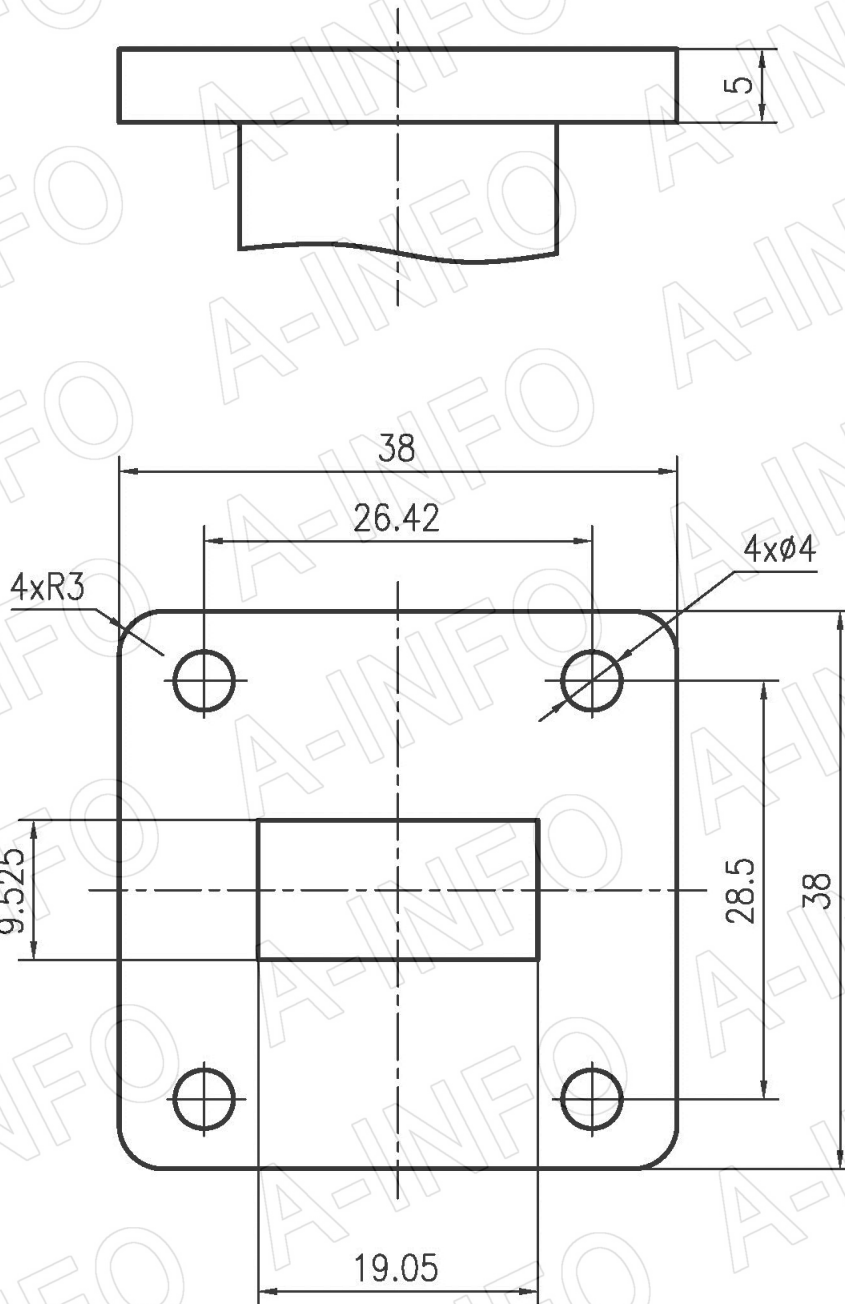

FBP120

AINFO Inc.

Page 2 of 3

China(Beijing): Tel: (+86) 10-6266-7326,
China(Chengdu): Tel: (+86) 28-8519-2786,
USA: Tel: (+1) 949-639-9688,

(+86) 10-6266-7327 Fax: (+86) 10-6266-7379
(+86) 28-8519-3044 Fax: (+86) 28-8519-3068
(+1) 949-639-9608 Fax: (+1) 949-639-9670

Website: www.ainfoinc.com
Email: sales@ainfoinc.com

Test Results

Attenuation (I.L.: 0.2980dB/m Max.)

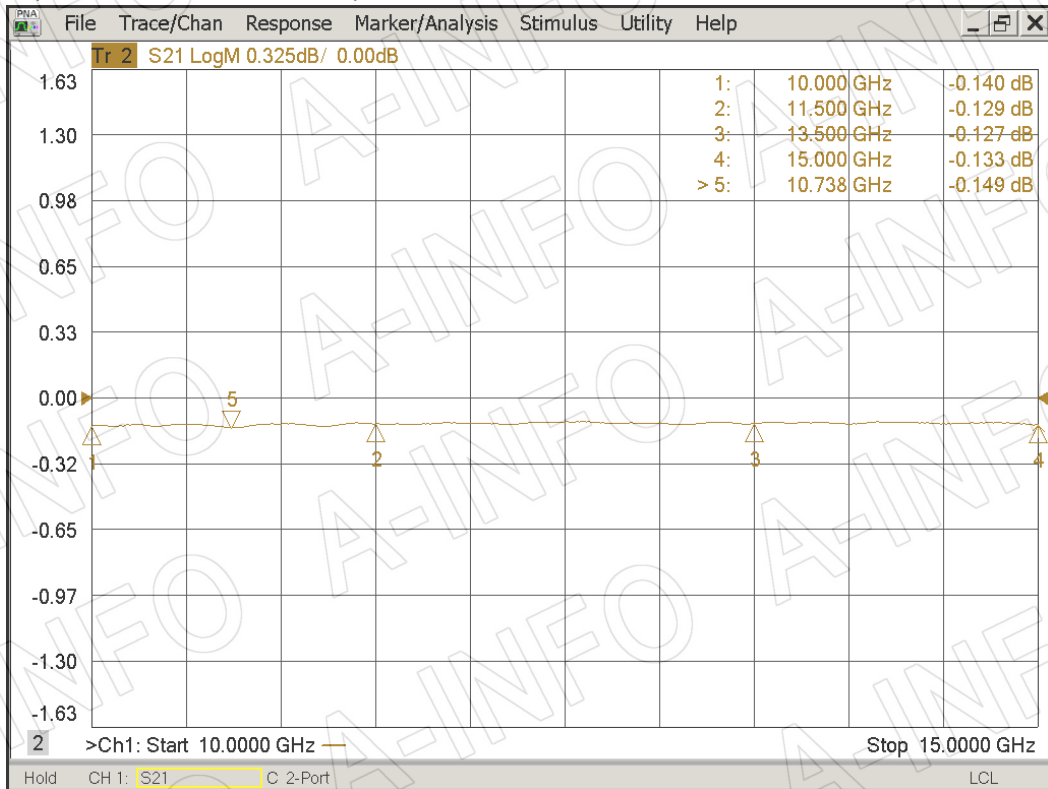

VSWR

